

HOW TO ORDER REPLACEMENT PARTS

To order replacement parts, contact the ICON Health & Fitness Ltd. office, or write:

ICON Health & Fitness Ltd.
Greenwich House
223 North Street
Sheepscar
Leeds LS7 2AA
West Yorkshire

Tel: Country Code: 0345-089009
Fax: 0113-2411120

When ordering parts, please be prepared to give the following information:

- The MODEL NUMBER OF THE PRODUCT (PETL61591)
- The NAME OF THE PRODUCT (PROFORM® 615 treadmill)
- The SERIAL NUMBER OF THE PRODUCT (see the front cover of this manual)
- The KEY NUMBER OF THE PART(S) (see the PART LIST on page 23 and the EXPLODED DRAWING attached in the centre of this manual)
- The DESCRIPTION OF THE PART(S) (see the PART LIST on page 23 and the EXPLODED DRAWING attached in the centre of this manual).

PROFORM® is a registered trademark of ICON Health & Fitness, Inc.

PRO·FORM® 615

USER'S MANUAL

Model No. PETL61591
Serial No. _____

Find the serial number in the location shown below. Write the serial number in the space above for reference.

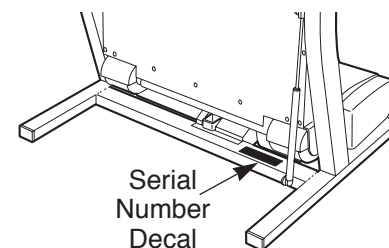

QUESTIONS?

As a manufacturer, we are committed to providing complete customer satisfaction. If you have questions, or if there are missing parts, we will guarantee complete satisfaction through our Customer Service Department.

Please CALL:

0345-089009

Or WRITE:
ICON Fitness Lifestyle Ltd.
Greenwich House
223 North Street
Sheepscar
Leeds LS7 2AA
West Yorkshire

⚠ CAUTION

Read all precautions and instructions in this manual before using this equipment. Save this manual for future reference.

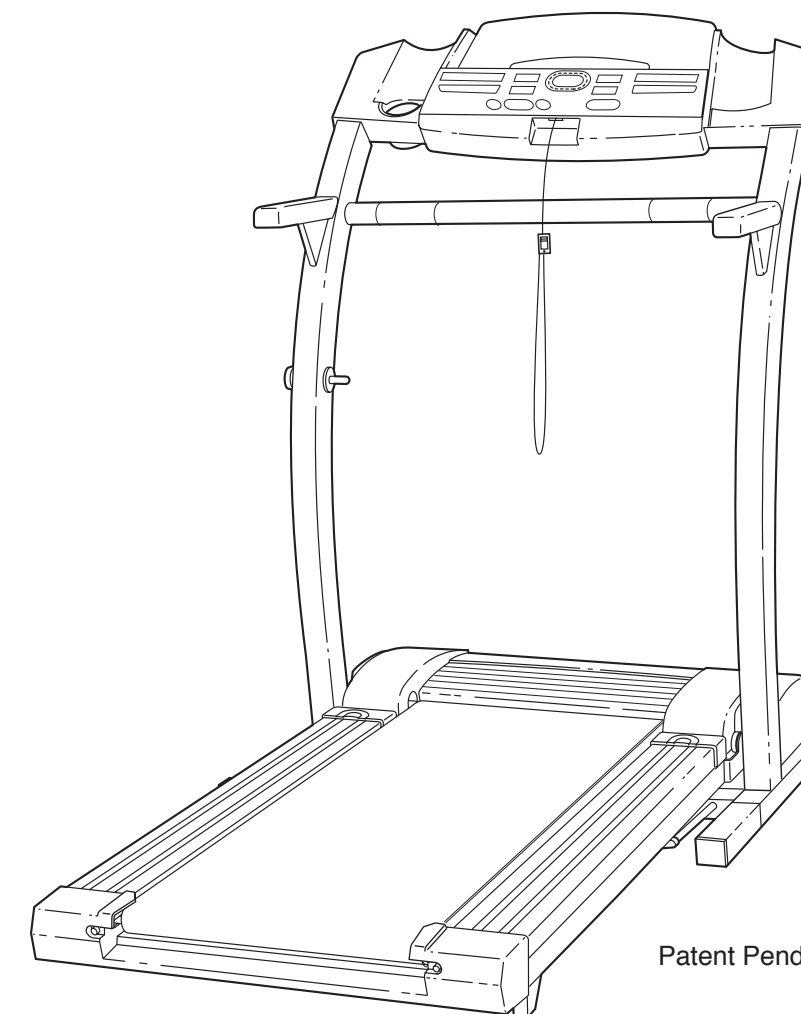

Visit our website at

www.proform.com

new products, prizes,
fitness tips, and much more!

PRO-FORM® 615

PART LIST—Model No. PETL61591

R1000A

To locate the parts listed below, refer to the EXPLODED DRAWING attached in the centre of this manual.

TABLE OF CONTENTS

IMPORTANT PRECAUTIONS	2
BEFORE YOU BEGIN	5
ASSEMBLY	6
OPERATION AND ADJUSTMENT	8
HOW TO FOLD AND MOVE THE TREADMILL	19
TROUBLE-SHOOTING	20
CONDITIONING GUIDELINES	22
PART LIST	23
HOW TO ORDER REPLACEMENT PARTS	Back Cover

Note: An EXPLODED DRAWING is attached in the centre of this manual.

IMPORTANT PRECAUTIONS

⚠ WARNING: To reduce the risk of burns, fire, electric shock, or injury to persons, read the following important precautions and information before operating the treadmill.

- It is the responsibility of the owner to ensure that all users of this treadmill are adequately informed of all warnings and precautions.
- Use the treadmill only as described in this manual.
- Place the treadmill on a level surface, with 2 m (eight feet) of clearance behind it. Do not place the treadmill on any surface that blocks air openings. To protect the floor or carpet from damage, place a mat under the treadmill.
- When choosing a location for the treadmill, make sure that the location and position permit access to a plug.
- Keep the treadmill indoors, away from moisture and dust. Do not put the treadmill in a garage or covered patio, or near water.
- Do not operate the treadmill where aerosol products are used or where oxygen is being administered.
- Keep children under the age of 12 and pets away from the treadmill at all times.
- The treadmill should not be used by persons weighing more than 115 kg (250 pounds).
- Never allow more than one person on the treadmill at a time.
- Wear appropriate exercise clothing when using the treadmill. Do not wear loose clothing that could become caught in the treadmill. Athletic support clothes are recommended for both men and women. Always wear athletic shoes. Never use the treadmill with bare feet, wearing only stockings, or in sandals.

Key No.	Qty.	Description	Key No.	Qty.	Description	Key No.	Qty.	Description
1	1	Motor Belt	50	1	Book Holder	102	1	Lock Knob
2	1	Pulley/Flywheel/Fan	51	1	Front Belly Pan	103	2	Extension Leg
3	4	Motor Nut	52	1	Power Supply	104	2	Extension Leg Cap
4*	1	Motor/Pulley/ Flywheel/ Fan	53	4	Cable Tie Clamp	105	1	Shock
5	1	Incline Motor Bolt	54	4	Cable Tie	106	1	Choke
6	1	Plastic Incline Motor Spacer	55	1	Walking Belt	107	2	Pulse Bar Bolt
7	1	Incline Motor	56	1	24" Wire Harness	108	2	Pulse Bar Washer
8	1	Stop Bracket	57	1	Rear Roller	109	1	Pulse Bar
9	1	Small Nut	58	1	Belly Pan Spacer	110	2	Handrail Foam Grip
10	2	Star Washer	59	2	Rear Foot	111	1	Lock Knob Sleeve
11	1	Optic Switch	60	1	Rear Foot Screw	112	1	Spring
12	1	Frame	61	1	Ground Wire	113	1	Lock Pin Collar
13	1	Optic Switch Bolt	62	13	Ground Wire Screw	114	1	Pin Clip
14	1	Incline Optic Disk	63	1	Belly Pan	115	1	Lock Pin
15	8	Incline Motor Nut	64	1	Rear Endcap	116	1	Console Base Bottom
16	2	Hood Screw	65	2	Rear Roller Adj. Bolt	117	2	Upright Endcap
17	4	Plastic Stand-off	66	1	Motor	118	1	Motor Sleeve
18	2	Hood Bracket (Short)	67	1	Latch Decal	119	8	Hood Bracket Screw/ Incline Shield Screw
19	1	Hood Bracket (Long)	68	4	Platform Screw	120	1	Rear Foot Spacer
20	2	Warning Decal	69	3	Electronics Screw	121**	1	Hand Weight Set
21	1	Reed Switch	70	1	Latch Catch	122	1	Long Incline Motor Bolt
22	1	Reed Switch Clip	71	1	Walking Platform	123	2	Static Warning
23	1	Motor/Controller Wire	72	5	8" Cable Tie	124	1	Hand Pulse Wire
24	1	Controller	73	1	Jack	125	1	Motor/Choke Bracket
25	1	Electronics Bracket	74	1	Motor Tension Bolt	126	1	Filter
26	1	Circuit Breaker	75	2	Foot Rail Insert	127	1	UK Power Cord
27	1	Receptacle	76	14	Screw	128	1	Euro Power Cord
28	1	Extension Leg Assm.	77	1	Console	129**	1	Chest Pulse Sensor
29	1	On/Off Switch	78	1	Motor Isolator Plate	130**	1	Chest Pulse Sensor Strap
30	1	Inlet Bracket	79	4	Long Screw	#	1	15" Wire Harness
31	1	Incline Leg	80	1	10' I-Fit Wire	#	1	8" White Wire, 2F
32	2	Frame Pivot Bolt	81	4	Motor Star Bushing	#	1	14" White Wire, 2F
33	2	Frame Pivot Spacer	82	1	Upright	#	1	8" Black M/F
34	1	Upright Wire Harness	83	2	Incline Leg Pivot Bolt	#	1	8" Blue Wire, 2F
35	1	Front Roller Adj. Bolt	84	2	Side Hood Screw	#	1	4" Blue Wire, 2F
36	3	Roller Adj. Washer	85	2	Handrail Extension	#	1	4" Black Wire, 2F
37	2	Motor Tension Nut/ Front Roller Nut	86	2	Wheel Bolt	#	1	6" Green Wire, F/Ring
38	4	Motor Bolt	87	1	Console Base	#	1	8" Green Wire, F/Ring
39	2	Cap Screw	88	1	Motor Tension Washer	#	1	8" Green Wire, 2 Ring
40	1	Left Foot Rail Cap	89	10	Console/Catch Screw	#	1	14" Blue 2F
41	2	Foot Rail	90	1	Key/Clip	#	1	25" Wire Harness
42	1	Front Roller/Pulley	91	1	Incline Motor Plate	#	1	User's Manual
43	1	Magnet	92	1	Right Foot Rail Cap	#	1	
44	2	Platform Screw (Mid)	93	1	Motor Tension Spacer	#	1	
45	2	Isolator	94	1	Motor Hood			
46	4	Isolator Screw	95	2	Front Wheel			
47	15	Plastic Fastener	96	1	Incline Motor Shield			
48	1	Shield	97	4	Thick Base Pad			
49	2	Belt Guide	98	1	12" Audio Wire			
			99	1	Upright Grommet			
			100	1	Allen Wrench			
			101	11	Short Screw			

* Includes all parts shown in the box

**For more information about the optional hand weight set, see page 18

These parts are not illustrated

CONDITIONING GUIDELINES

⚠ WARNING: Before beginning this or any exercise program, consult your physician. This is especially important for individuals over the age of 35 or individuals with pre-existing health problems.

The pulse sensor is not a medical device. Various factors, including your movement, may affect the accuracy of heart rate readings. The sensor is intended only as an exercise aid in determining heart rate trends in general.

The following guidelines will help you to plan your exercise program. Remember—these are general guidelines only. For more detailed exercise information, obtain a reputable book or consult your physician.

EXERCISE INTENSITY

Whether your goal is to burn fat or to strengthen your cardiovascular system, the key to achieving the desired results is to exercise with the proper intensity. The proper intensity level can be found by using your heart rate as a guide. The chart below shows recommended heart rates for fat burning and aerobic exercise.

	165	155	145	140	130	125	115
AEROBIC							
MAX FAT BURN	145	138	130	125	118	110	103
FAT BURN	125	120	115	110	105	95	90
Age	20	30	40	50	60	70	80

To find the proper heart rate for you, first find your age near the bottom of the chart (ages are rounded off to the nearest ten years). Next, find the three numbers above your age. The three numbers define your “training zone.” The lower two numbers are recommended heart rates for fat burning; the higher number is the recommended heart rate for aerobic exercise.

To measure your heart rate during exercise, use the pulse sensor. If your heart rate is too high or too low, adjust the speed and incline of the treadmill.

Fat Burning

To burn fat effectively, you must exercise at a relatively low intensity level for a sustained period of time. During the first few minutes of exercise, your body uses easily accessible carbohydrate calories for en-

ergy. Only after the first few minutes does your body begin to use stored fat calories for energy. If your goal is to burn fat, adjust the speed and incline of the treadmill until your heart rate is near the lowest number in your training zone.

For maximum fat burning, adjust the speed and incline of the treadmill until your heart rate is near the middle number in your training zone.

Aerobic Exercise

If your goal is to strengthen your cardiovascular system, your exercise must be “aerobic.” Aerobic exercise is activity that requires large amounts of oxygen for prolonged periods of time. This increases the demand on the heart to pump blood to the muscles, and on the lungs to oxygenate the blood. For aerobic exercise, adjust the speed and incline of the treadmill until your heart rate is near the highest number in your training zone.

WORKOUT GUIDELINES

Each workout should include the following three parts:

A Warm-up—Start each workout with 5 to 10 minutes of stretching and light exercise. A proper warm-up increases your body temperature, heart rate and circulation in preparation for exercise.

Training Zone Exercise—After warming up, increase the intensity of your exercise until your pulse is in your training zone for 20 to 60 minutes. (During the first few weeks of your exercise program, do not keep your pulse in your training zone for longer than 20 minutes.) Breathe regularly and deeply as you exercise—never hold your breath.

A Cool-down—Finish each workout with 5 to 10 minutes of stretching to cool down. This will increase the flexibility of your muscles and will help prevent post-exercise problems.

Exercise Frequency

To maintain or improve your condition, complete three workouts each week, with at least one day of rest between workouts. After a few months, you may complete up to five workouts each week if desired.

The key to success is to make exercise a regular and enjoyable part of your everyday life.

- When connecting the power cord (see page 8), plug the power cord into an earthed circuit. When replacing the fuse, an ASTA approved BS1362 type should be fitted to the fuse carrier. A 13 amp fuse should be used. No other appliance should be on the same circuit.
- If an extension cord is needed, use only a 3-conductor, 1mm² (14 gauge) cord that is no longer than 1.5 meters (5 feet).
- Keep the power cord away from heated surfaces.
- Never move the walking belt whilst the power is turned off. Do not operate the treadmill if the power cord or plug is damaged, or if the treadmill is not working properly. (See BEFORE YOU BEGIN on page 5 if the treadmill is not working properly.)
- Never start the treadmill whilst you are standing on the walking belt. Always hold the handrails whilst using the treadmill.
- The treadmill is capable of high speeds. Adjust the speed in small increments to avoid sudden jumps in speed.
- The pulse sensor is not a medical device. Various factors may affect the accuracy of heart rate readings. The pulse sensor is intended only as an exercise aid in determining heart rate trends in general.
- Never leave the treadmill unattended whilst it is running. Always remove the key, unplug the power cord and move the on/off switch to the off position when the treadmill is not in use. (See the drawing on page 5 for the location of the on/off switch.)
- Do not attempt to raise, lower, or move the treadmill until it is properly assembled. (See ASSEMBLY on page 6, and HOW TO MOVE THE TREADMILL on page 19.) You must be able to safely lift 20 kg (45 pounds) in order to raise, lower, or move the treadmill.

- Do not change the incline of the treadmill by placing objects under the treadmill.
- When folding or moving the treadmill, make sure that the latch pin is fully inserted into the catch (see page 19).
- Inspect and tighten all parts of the treadmill regularly.
- When using i-Fit.com CD's and videos, an electronic “chirping” sound will alert you when the speed and/or incline of the treadmill is about to change. Always listen for the “chirp” and be prepared for speed and/or incline changes. In some instances, the speed and/or incline may change before the personal trainer describes the change.
- When using i-Fit.com CD's and videos, you can manually override the speed and incline settings at any time by pressing the speed and incline buttons. However, when the next “chirp” is heard, the speed and/or incline will change to the next settings of the CD or video program.
- Always remove i-Fit.com CD's and videos from your CD player or VCR when you are not using them.
- Never drop or insert any object into any opening.
- DANGER:** Always unplug the power cord immediately after use, before cleaning the treadmill, and before performing the maintenance and adjustment procedures described in this manual. Never remove the motor hood unless instructed to do so by an authorised service representative. Servicing other than the procedures in this manual should be performed by an authorised service representative only.
- The treadmill is intended for in-home use only. Do not use the treadmill in a commercial, rental, or institutional setting.

⚠ WARNING: Before beginning this or any exercise program, consult your physician. This is especially important for persons over the age of 35 or persons with pre-existing health problems. Read all instructions before using. ICON assumes no responsibility for personal injury or property damage sustained by or through the use of this product.

SAVE THESE INSTRUCTIONS

The decals shown below have been placed on your treadmill. If a decal is missing or illegible, please call our Customer Service Department to order a free replacement decal (see the front cover of this manual). Apply the decal in the location shown.

⚠ WARNING: Protect yourself and others from risk of serious injury. Read the user's manual and:

- Fully engage storage latch before treadmill is moved or stored.
- Reduce incline to lowest level before folding treadmill into storage position.
- Stand only on side rails when starting or stopping treadmill.
- Change speed in small increments.
- Hold handrails to prevent falling, and always wear the safety clip while operating treadmill.
- Stop if you feel faint, dizzy, or short of breath.
- Never allow children on or around treadmill.
- Remove key when not in use.
- Keep clothing, fingers, and hair away from moving belt.
- Never try to adjust or fix the belt while it is moving.
- Always wear athletic shoes while operating treadmill.

Note: This decal is shown at 38% of actual size.

⚠ CAUTION
KEEP HANDS AND FEET AWAY FROM THIS AREA WHILE THE TREADMILL IS IN OPERATION.

Note: This decal is shown at 20% of actual size.

⚠ WARNING Do not remove or insert this plug while the key is inserted in the console. Static sensitive components may be affected.

⚠ WARNUNG Dieser Stecker darf nicht entfernt oder eingesteckt werden während der Schlüssel im Computer eingesteckt ist. Statik empfindliche Komponente könnten beeinflusst werden.

⚠ ATTENZIONE Non rimuovere o inserire questa presa mentre la chiave è inserita nella console. I componenti statico-sensibili potrebbero esserne compromessi.

⚠ AVERTISSEMENT Ne retirez pas ou n'insérez pas la prise si la clé est insérée dans la console. Certaines des pièces électroniques peuvent être sensibles à la statique.

⚠ ADVERTENCIA No quite o inserte este enchufe mientras que la llave esté insertada en la consola. Componentes sensibles a la estática pueden ser afectadas.

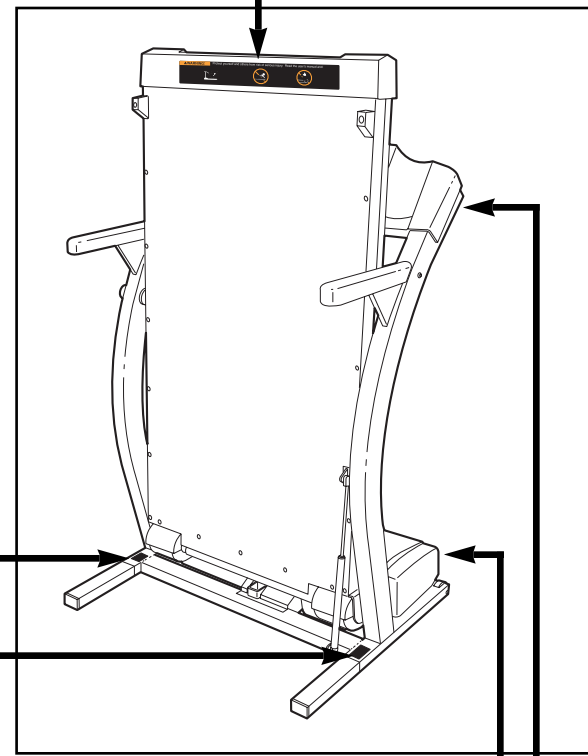

PROBLEM: The walking belt slows when walked on

SOLUTION: a. If an extension cord is needed, use only a 3-conductor, 14-gauge (1mm²) cord that is no longer than 1.5 meters (5 feet).

b. If the walking belt is overtightened, treadmill performance may decrease and the walking belt may become damaged. Remove the key and **UNPLUG THE POWER CORD**. Using the allen wrench, turn both rear roller adjustment bolts counterclockwise, 1/4 of a turn. When the walking belt is properly tightened, you should be able to lift each side of the walking platform 5 to 7 cm off the walking belt. Be careful to keep the walking belt centred. Plug in the power cord, insert the key and run the treadmill for a few minutes. Repeat until the walking belt is properly tightened.

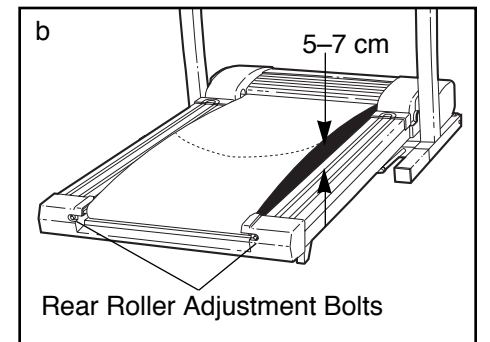

c. If the walking belt still slows when walked on, please call our Customer Service Department.

PROBLEM: The walking belt is off-centre

SOLUTION: a. If the walking belt has shifted to the left, first remove the key and **UNPLUG THE POWER CORD**. Using the allen wrench, turn the left rear roller adjustment bolt clockwise, and the right bolt counterclockwise, 1/4 of a turn each. Be careful not to overtighten the walking belt. Plug in the power cord, insert the key and run the treadmill for a few minutes. Repeat until the walking belt is centred.

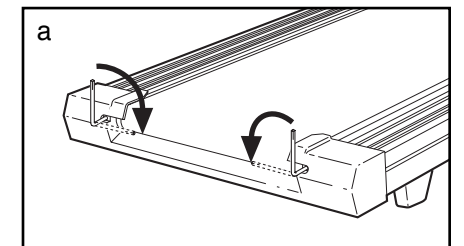

b. If the walking belt has shifted to the right, first remove the key and **UNPLUG THE POWER CORD**. Using the allen wrench, turn the left rear roller adjustment bolt counterclockwise, and the right bolt clockwise, 1/4 of a turn each. Be careful not to overtighten the walking belt. Plug in the power cord, insert the key and run the treadmill for a few minutes. Repeat until the walking belt is centred.

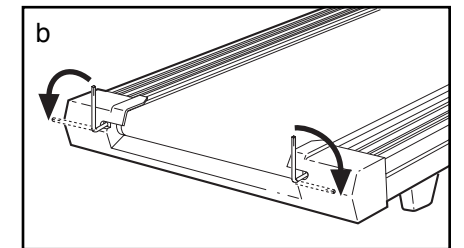

PROBLEM: The walking belt slips when walked on

SOLUTION: a. If the walking belt slips when walked on, first remove the key and **UNPLUG THE POWER CORD**. Using the allen wrench, turn both rear roller adjustment bolts clockwise, 1/4 of a turn. When the walking belt is correctly tightened, you should be able to lift each side of the walking platform 5 to 7 inches off the walking belt. Be careful to keep the walking belt centred. Plug in the power cord, insert the key and carefully walk on the treadmill for a few minutes. Repeat until the walking belt is properly tightened.

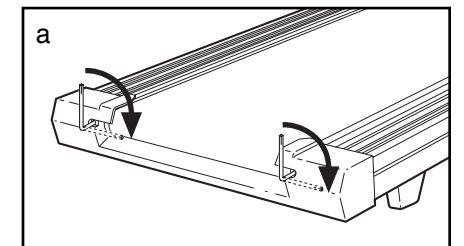

PROBLEM: The incline of the treadmill does not change correctly or does not change when i-Fit.com CD's and videos are played

SOLUTION: a. With the key inserted in the console, press one of the INCLINE buttons. **While the incline is changing, remove the key.** After a few seconds, re-insert the key. The treadmill will automatically rise to the maximum incline level and then return to the minimum level. This will recalibrate the incline.

TROUBLE-SHOOTING

Most treadmill problems can be solved by following the steps below. Find the symptom that applies, and follow the steps listed. If further assistance is needed, please call our Customer Service Department.

PROBLEM: The power does not turn on

SOLUTION: a. Make sure that the power cord is plugged into a properly earthed outlet. (See HOW TO PLUG IN THE POWER CORD on page 8.) If an extension cord is needed, use only a 3-conductor, 14-gauge (1mm²) cord that is no longer than 1.5 meters (5 feet). Important: The treadmill is not compatible with GFCI-equipped outlets.

b. After the power cord has been plugged in, make sure that the key is fully inserted into the console. See step 1 on page 10.

c. Check the circuit breaker located on the treadmill near the power cord. If the switch protrudes as shown, the circuit breaker has tripped. To reset the circuit breaker, wait for five minutes and then press the switch back in.

d. Check the on/off switch located on the treadmill near the power cord. The switch must be in the on position.

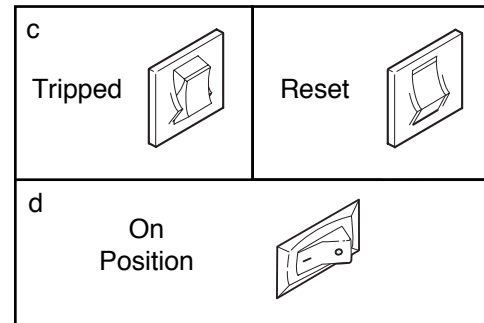

PROBLEM: The power turns off during use

SOLUTION: a. Check the circuit breaker located on the treadmill frame near the power cord (see c. above). If the circuit breaker has tripped, wait for five minutes and then press the switch back in.

b. Make sure that the power cord is plugged in.

c. Remove the key from the console. Reinsert the key fully into the console. See step 1 on page 10.

d. Make sure that the on/off switch is in the on position.

e. If the treadmill still will not run, please call our Customer Service Department.

PROBLEM: The speed display on the console does not function properly

SOLUTION: a. Remove the key from the console and **UNPLUG THE POWER CORD**. Remove the screws from the hood and carefully remove the hood. Locate the Reed Switch (21) and the Magnet (43) on the left side of the Pulley (42). Turn the Pulley until the Magnet is aligned with the Reed Switch. **Make sure that the gap between the Magnet and the Reed Switch is about 3mm.** If necessary, loosen the Screw (76) and move the Reed Switch slightly. Retighten the Screw. Re-attach the hood, and run the treadmill for a few minutes to check for a correct speed reading.

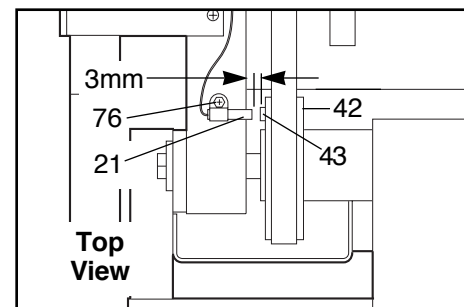

BEFORE YOU BEGIN

Thank you for selecting the revolutionary PROFORM® 615 treadmill. The PROFORM® 615 combines advanced technology with innovative design to help you get the most from your exercise program in the convenience and privacy of your home. And when you're not exercising, the unique treadmill can be folded up, requiring less than half the floor space of other treadmills.

For your benefit, read this manual carefully before using the PROFORM® 615 treadmill. If you have additional questions, please call our our Customer

Service Department at 0345-089009. To help us assist you, please note the product model number and serial number before calling. The model number of the treadmill is PETL61591. The serial number can be found on a decal attached to the treadmill (see the front cover of this manual for the location).

Before reading further, please review the drawing below and familiarise yourself with the parts that are labeled.

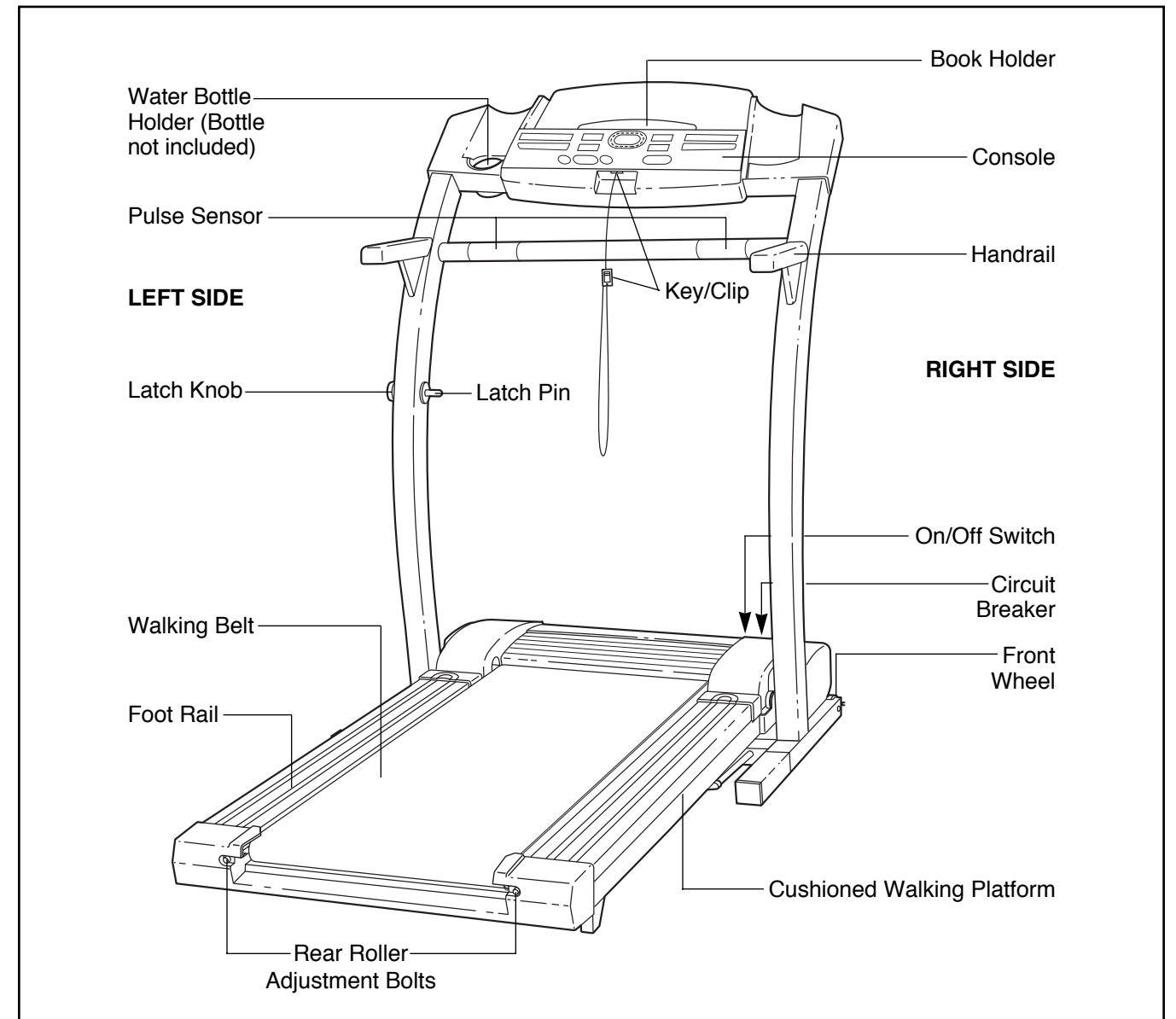

ASSEMBLY

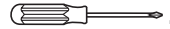
Assembly requires two people. Set the treadmill in a cleared area and remove all packing materials. Do not dispose of the packing materials until assembly is completed. **Assembly requires the included allen wrench and your own phillips screwdriver** .

Note: The underside of the treadmill walking belt is coated with high-performance lubricant. During shipping, a small amount of lubricant may be transferred to the top of the walking belt or the shipping carton. This is a normal condition and does not affect treadmill performance. If there is lubricant on top of the walking belt, simply wipe off the lubricant with a soft cloth and a mild, non-abrasive cleaner.

1. With the help of a second person, carefully raise the treadmill to the upright position.

While a second person tips the treadmill to one side and holds it, insert one of the Extension Legs (103) into the treadmill as shown. Make sure that the Extension Leg is turned so the Thick Base Pad (97) is on the bottom.

Next, tip the treadmill to the other side and insert the other Extension Leg (not shown) in the same way. Lower the side of the treadmill so that both Extension Legs (103) are resting flat on the floor.

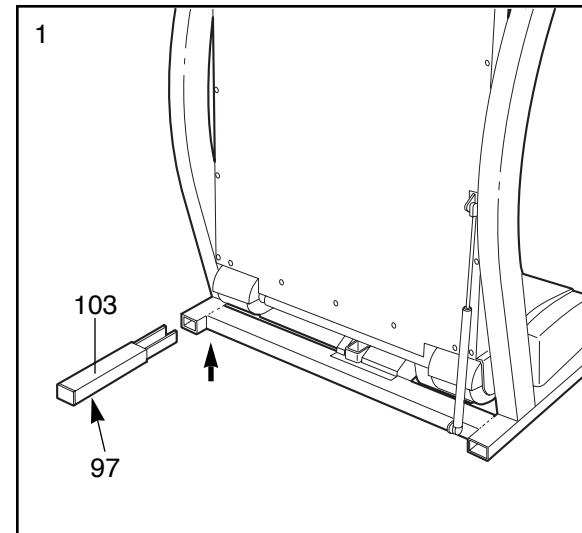

2. With the help of a second person, carefully tip the Uprights (82) down as shown. **Make sure that the Extension Legs (103) remain in the Uprights.**

Attach each Extension Leg (103) with two Screws (76) and a Base Pad (118) as shown.

With the help of a second person, carefully tip the Uprights (82) back to the vertical position.

Note: One replacement Base Pad (118) may be included. Use the Base Pad to replace any Base Pad that becomes worn.

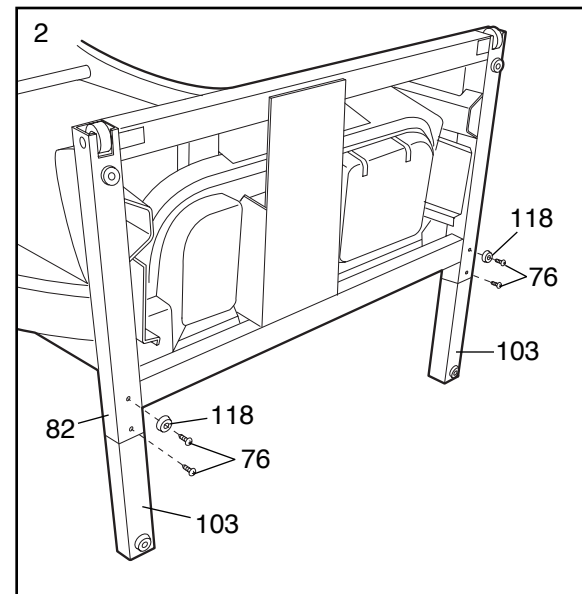

HOW TO FOLD AND MOVE THE TREADMILL

HOW TO FOLD THE TREADMILL FOR STORAGE

Before folding the treadmill, adjust the incline to the lowest position. If this is not done, the treadmill may be permanently damaged. Next, unplug the power cord. **CAUTION: You must be able to safely lift 20 kg (45 pounds) in order to raise, lower, or move the treadmill.**

1. Hold the treadmill with your hands in the locations shown at the right. **CAUTION: To decrease the possibility of injury, bend your legs and keep your back straight. As you raise the treadmill, make sure to lift with your legs rather than your back.** Raise the treadmill about halfway to the vertical position.

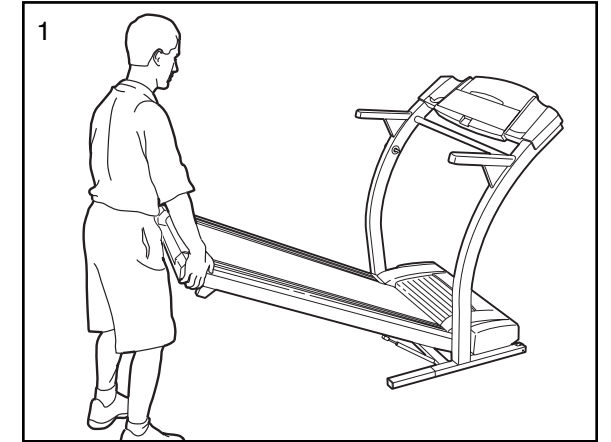

2. Move your right hand to the position shown and hold the treadmill firmly. Using your left hand, pull the latch knob to the left and hold it. Raise the treadmill until the latch pin is aligned with the hole in the catch. Insert the latch pin into the catch. **Make sure that the latch pin is fully inserted into the catch.**

To protect the floor or carpet from damage, place a mat under the treadmill. Keep the treadmill out of direct sunlight. Do not leave the treadmill in the storage position in temperatures above 30° Celsius.

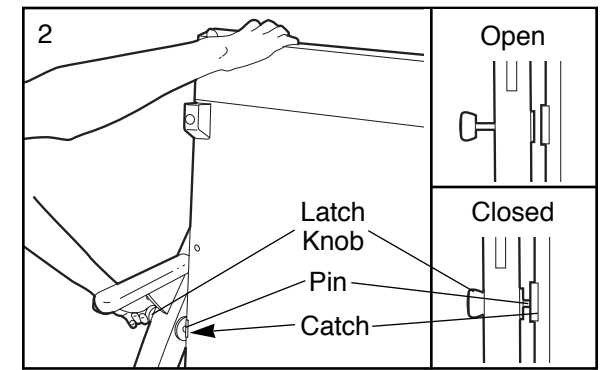

HOW TO MOVE THE TREADMILL

Before moving the treadmill, convert the treadmill to the storage position as described above. **Make sure that the latch pin is fully inserted into the catch.**

1. Hold the handrails as shown and place one foot against a wheel.
2. Tilt the treadmill back until it rolls freely on the front wheels. Carefully move the treadmill to the desired location. **Never move the treadmill without tipping it back. To reduce the risk of injury, use extreme caution while moving the treadmill. Do not attempt to move the treadmill over an uneven surface.**
3. Place one foot on the base, and carefully lower the treadmill until it is resting in the storage position.



HOW TO LOWER THE TREADMILL FOR USE

1. Refer to drawing 2 above. Hold the treadmill with your right hand as shown. Using your left hand, pull the latch knob to the left and hold it. Pivot the treadmill down until the frame is past the pin. Slowly release the latch knob.
2. Refer to drawing 1. Hold the treadmill firmly with both hands, and lower the treadmill to the floor. **CAUTION: To decrease the possibility of injury, bend your legs and keep your back straight.**

8 Follow your progress with the LED track and the four displays.

See step 5 on page 10.

9 Measure your pulse, if desired.

See step 6 on page 11.

10 When the program is finished, remove the key.

Step onto the foot rails and remove the key from the console. Keep the key in a secure place.

Note: If the displays and various indicators on the console remain lit after the key is removed, the console is in the “demo” mode. Refer to the instructions at the right and turn off the demo mode.

When you are finished using the treadmill, move the on/off switch near the power cord to the off position.

IMPORTANT: The CALS/FAT CALS/PULSE display should be blank. If a “d” appears in the display, the console is in the “demo” mode. This mode is intended to be used only when a treadmill is displayed in a store. When the console is in the demo mode, the power cord can be plugged in, the key can be removed from the console, and the displays and indicators on the console will automatically light in a preset sequence, although the buttons on the console will not operate. **If a “d” appears in the CALS/FAT CALS/PULSE display when the information mode is selected, press the SPEED ▽ button so the CALS/FAT CALS/PULSE display is blank.**

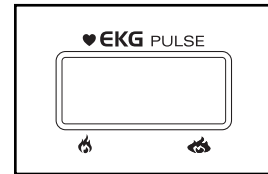
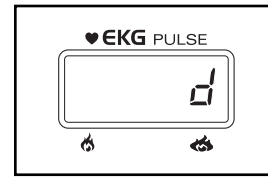

To exit the information mode, remove the key from the console.

OPTIONAL HAND WEIGHTS

Optional hand weights let you include upper-body exercise in your workouts. The hand weights fit into convenience holders in the console. **To purchase the optional hand weights, call the Customer Service Department (see the back cover of this manual).**

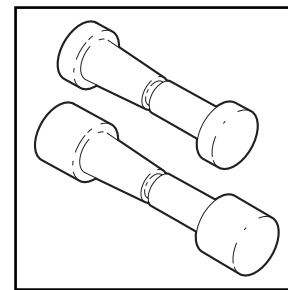

OPTIONAL CHEST PULSE SENSOR

An optional chest pulse sensor adds even more features to the console. The chest pulse sensor offers hands-free operation and continuously monitors your heart rate during your workouts. **To purchase the optional chest pulse sensor, call our Customer Service Department (see the back cover of this manual).**

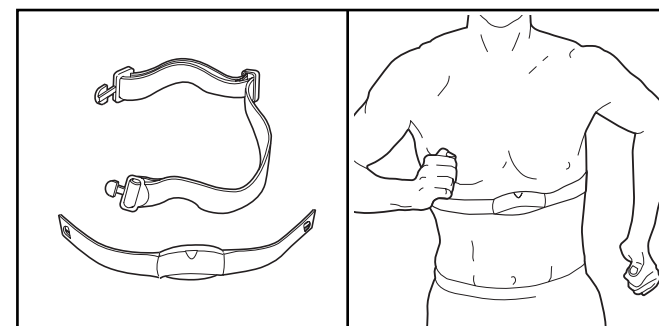

THE INFORMATION MODE/DEMO MODE

The console features an information mode that keeps track of the total number of hours that the treadmill has been operated and the total number of miles that the walking belt has moved. The information mode also allows you to switch the console from miles per hour to kilometers per hour. In addition, the information mode allows you to turn on and turn off the demo mode.

To select the information mode, hold down the STOP button while inserting the key into the console. When the information mode is selected, the following information will be shown:

The DISTANCE/LAPS display will show the total number of miles that the walking belt has moved.



The TIME/INCLINE/SEG TIME display will show the total number of hours the treadmill has been used.



An “E,” for english miles, or an “M,” for metric kilometers, will appear in the SPEED/ MIN-MILE display. Press the SPEED△ button to change the unit of measurement.

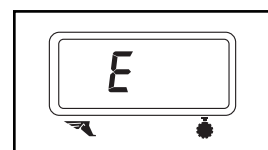

3. Locate the plastic tie in the post on the left Upright (82). Hold a Handrail Extension (85) in the position shown. Insert the plastic tie into the Handrail Extension as you insert the Handrail Extension into the post. Attach the Handrail Extension with three Screws (76). **Note: The plastic tie is tied to the Hand Pulse Wire (124). Be careful to avoid damaging the Hand Pulse Wire. The Hand Pulse Wire is used with the optional chest pulse sensor (see page 18).**

Slide a Handrail Foam Grip (110) onto the Handrail Extension (85). (If it is difficult to slide on the Foam Grip, place a small amount of warm water and dish soap in the Foam Grip.) There are one or two holes in the bottom of the Foam Grip. Press a Plastic Fastener (47) into each hole.

Attach the other Handrail Extension and Handrail Foam Grip to the right Upright (not shown). Note: There is not a wire harness in the right Upright.

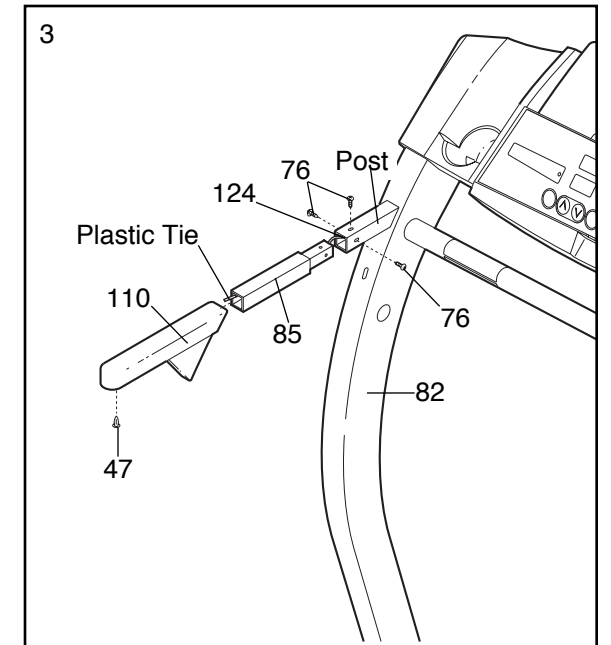

4. Make sure that the Lock Knob Sleeve (111) is fully inserted into the left Upright (82).

Remove the Lock Knob (102) from the Lock Pin (115). Make sure that the Lock Pin Collar (113) and the Spring (112) are on the Lock Pin. Insert the Lock Pin into the left Upright (82) and tighten the Lock Knob onto it.

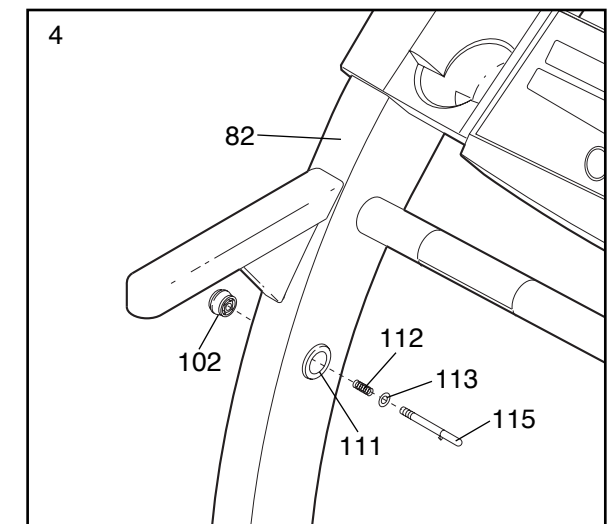

5. **Make sure that all parts are tightened before you use the treadmill.** Keep the included allen wrench in a secure place. The allen wrench is used to adjust the walking belt (see page 21). To protect the floor or carpet from damage, place a mat under the treadmill.

OPERATION AND ADJUSTMENT

THE PERFORMANT LUBE™ WALKING BELT

Your treadmill features a walking belt coated with PERFORMANT LUBE™, a high-performance lubricant. **IMPORTANT: Never apply silicone spray or other substances to the walking belt or the walking platform. They will deteriorate the walking belt and cause excessive wear.**

HOW TO PLUG IN THE POWER CORD

This product must be earthed. If it should malfunction or break down, earthing provides a path of least resistance for electric current to reduce the risk of electric shock. This product is equipped with a cord having an equipment-earthing conductor and a earthing plug.

Two power cords are included. Select the one that will fit your outlet. Refer to drawing 1. Plug the indicated end of the power cord into the socket on the treadmill. Refer to drawing 2. Plug the power cord into an appropriate outlet that is properly installed and earthed in accordance with all local codes and ordinances. Note: In Italy, an adapter (not included) must be used between the power cord and the outlet. Important: The treadmill is not compatible with GFCI-equipped outlets.

Use only a power cord type H05VV-F with a conductor of at least 1mm², with a country recognised plug and an appliance coupler.

⚠ DANGER: Improper connection of the equipment-earthing conductor can result in an increased risk of electric shock. Check with a qualified electrician or serviceman if you are in doubt as to whether the product is properly earthed. Do not modify the plug provided with the product—if it will not fit the outlet, have a proper outlet installed by a qualified electrician.

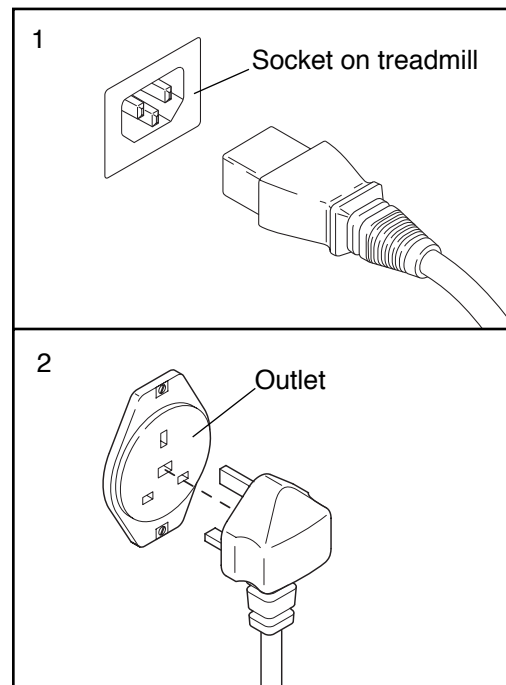

HOW TO USE PROGRAMS DIRECTLY FROM OUR INTERNET SITE

Our new internet site at www.iFit.com allows you to access a large selection of programs that interactively control your treadmill to help you achieve your specific exercise goals. In addition, you can play iFit.com audio and video programs directly from the internet. Explore www.iFit.com for details.

To use programs from our internet site, the treadmill must be connected to your home computer. See HOW TO CONNECT YOUR COMPUTER on page 14. In addition, you must have at least a 56K modem and an account with an internet service provider. A list of additional system and software requirements will be found on our internet site.

Next, make sure that the on/off switch near the power cord is in the on position. In addition, make sure that the power cord is properly plugged in (see HOW TO PLUG IN THE POWER CORD on page 8).

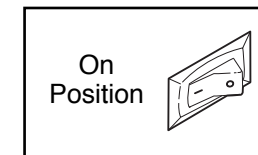

Follow the steps below to use a program from our internet site.

1 Insert the key fully into the console.

When the key is inserted, the four displays and various indicators on the console will light.

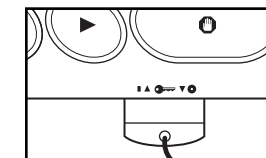

2 Press the PROGRAM button.

When the key is inserted, the manual mode will be selected. To use a program from our internet site, press the PROGRAM button. The iFit.com indicator will light.

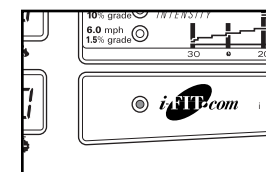

3 Go to your computer and start an internet connection.

4 Start your web browser, if necessary, and go to our internet site at www.iFit.com.

5 Follow the desired links on our internet site to select a program.

Read and follow the on-line instructions for using a program.

6 Follow the on-line instructions to start the program.

When you start the program, an on-screen countdown will begin.

7 Return to the treadmill and stand on the foot rails. Find the clip attached to the key and slide the clip onto the waistband of your clothing.

When the on-screen countdown ends, the program will begin and the walking belt will begin to move. Hold the handrails, step onto the walking belt, and begin walking.

During the program, an electronic “chirping” sound will alert you when the speed and/or incline of the treadmill is about to change. **CAUTION: Always listen for the “chirp” and be prepared for speed and/or incline changes.**

If the speed or incline settings are too high or too low, you can manually override the settings at any time by pressing the SPEED or INCLINE buttons on the console. However, **when the next “chirp” is heard, the speed and/or incline will change to the next settings of the program.**

To stop the program at any time, press the STOP button on the console. The TIME/INCLINE/SEG TIME display will begin to flash. To restart the program, press the START button or the SPEED Δ button on the console. After a moment, the walking belt will begin to move at 1.0 mph. **When the next “chirp” is heard, the speed and incline will change to the next settings of the program.**

When the program is completed, the walking belt will stop and the TIME/INCLINE/SEG TIME display will begin to flash. Note: To use another program, press the STOP button and go to step 5 above.

Note: If the speed or incline of the treadmill does not change when a “chirp” is heard, make sure that the iFit.com indicator is lit and that the TIME/INCLINE/SEG TIME display is not flashing. In addition, make sure that the audio cable is properly connected, that it is fully plugged in, and that it is not wrapped around a power cord.

4 Press the **PLAY** button on your CD player or VCR.

A moment after the button is pressed, your personal trainer will begin guiding you through your workout. Simply follow your personal trainer's instructions. Note: If the TIME/INCLINE/SEG TIME display is flashing, press the START button or the SPEED Δ button on the console. The treadmill will not respond to a CD or video program whilst the TIME/INCLINE/SEG TIME display is flashing.

During the CD or video program, an electronic "chirping" sound will alert you when the speed and/or incline of the treadmill is about to change. **CAUTION: Always listen for the "chirp" and be prepared for speed and/or incline changes. In some instances, the speed and/or incline may change before the personal trainer describes the change.**

If the speed or incline settings are too high or too low, you can manually override the settings at any time by pressing the SPEED or INCLINE buttons on the console. However, **when the next "chirp" is heard, the speed and/or incline will change to the next settings of the CD or video program.**

To stop the program at any time, press the STOP button on the console. The TIME/INCLINE/SEG TIME display will begin to flash. To restart the program, press the START button or the SPEED Δ button again. After a moment, the walking belt will begin to move at 1 mph. **When the next "chirp" is heard, the speed and incline will change to the next settings of the CD or video program.** The program can also be stopped by pressing the STOP button on your CD player or VCR.

When the CD or video program is completed, the walking belt will stop and the TIME/INCLINE/SEG TIME display will begin to flash. Note: To use another CD or video program, press the STOP button or remove the key and go to step 1 on page 15.

Note: If the speed or incline of the treadmill does not change when a "chirp" is heard:

- make sure that the iFit.com indicator is lit and that the TIME/INCLINE/SEG TIME display is not flashing. If the TIME/INCLINE/SEG TIME display is flashing, press the START button or the SPEED Δ button on the console
- adjust the volume of your CD player or VCR. If the volume is too high or too low, the console may not detect the program signals
- make sure that the audio cable is properly connected, that it is fully plugged in, and that it is not wrapped around a power cord
- if you are using your portable CD player and the CD skips, set the CD player on the floor or another flat surface instead of on the console.

5 Follow your progress with the LED track and the four displays.

See step 5 on page 10.

6 Measure your pulse, if desired.

See step 6 on page 11.

7 When the iFit.com CD or video program is finished, remove the key.

Step onto the foot rails and remove the key from the console. Keep the key in a secure place.

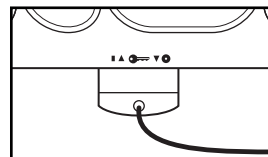

Note: If the displays and various indicators on the console remain lit after the key is removed, the console is in the "demo" mode. Refer to page 18 and turn off the demo mode.

CAUTION: Always remove iFit.com CD's and videocassettes from your CD player or VCR when you are finished using them.

When you are finished using the treadmill, move the on/off switch near the power cord to the off position.

CONSOLE DIAGRAM

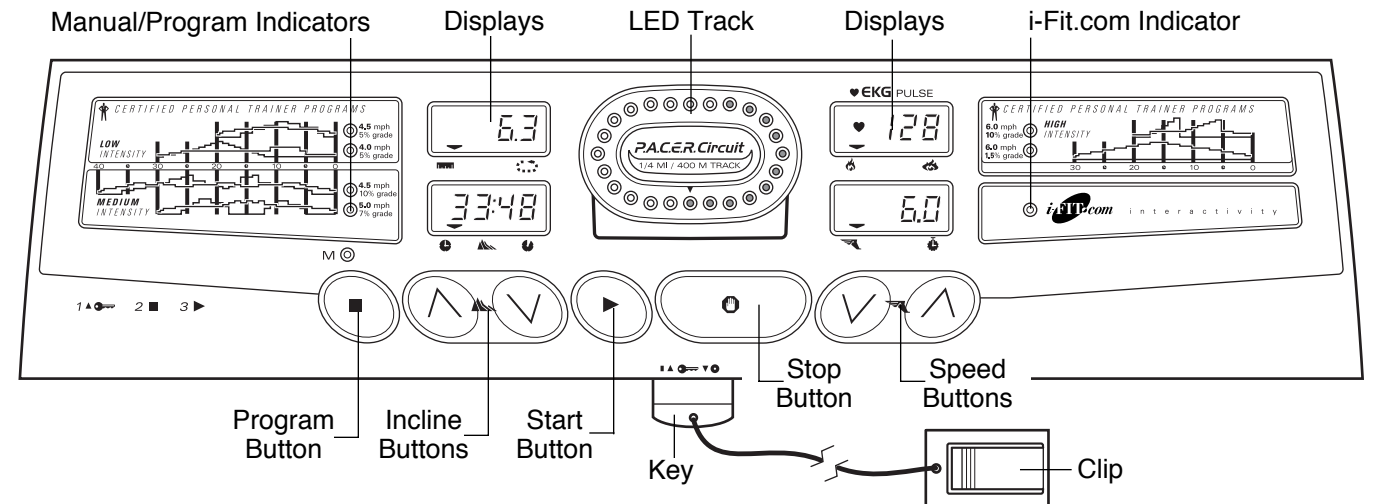

CAUTION: Before operating the console, read the following precautions.

- Do not stand on the walking belt when turning on the power.
- Always wear the clip (see the drawing above) whilst operating the treadmill.
- Adjust the speed in small increments to avoid sudden jumps in speed.
- To reduce the possibility of electric shock, keep the console dry. Avoid spilling liquids on the console and place only a sealed water bottle in the water bottle holder.

FEATURES OF THE CONSOLE

The treadmill console offers an impressive array of features to help you get the most from your exercise. When the console is in the manual mode, the speed and incline of the treadmill can be controlled with a touch of a button. As you exercise, the LED track and the four displays will provide continuous exercise feedback. You can even measure your heart rate using the built-in pulse sensor.

Six certified personal trainer programs are also offered. Each program automatically controls the speed and incline of the treadmill as it guides you through an effective workout.

The console also features advanced iFit.com interactive technology. iFit.com technology is like having a

personal trainer right in your home. Using the included audio cable, you can connect the treadmill to your home stereo, portable stereo, or computer and play special iFit.com CD programs (CD's are available separately). iFit.com CD programs automatically control the speed and incline of the treadmill as a personal trainer guides you through every step of your workout. High-energy music provides added motivation. Each CD features two different programs designed by certified personal trainers.

In addition, you can connect the treadmill to your VCR and TV and play iFit.com video programs (videocassettes are available separately). iFit.com video programs offer the same benefits as iFit.com CD programs, but add the excitement of working out with a class and an instructor—the hottest new trend at health clubs.

With the treadmill connected to your computer, you can also go to our new internet site at www.iFit.com and access even more programs. Choose from a selection of basic programs that interactively control the speed and incline of your treadmill to help you achieve your personal exercise goals. Or, use iFit.com audio and video programs directly from our internet site. Visit www.iFit.com for complete details.

See www.iFit.com to learn about other iFit.com features. To purchase iFit.com CD's, iFit.com videocassettes, call toll-free 0345-089009. For information about other optional accessories, see page 18.

To use the manual mode of the console, follow the steps beginning on page 10. **To use a personal trainer program**, see page 12. **To use iFit.com CD or video programs**, refer to page 15. **To use iFit.com programs directly from our internet site**, see page 17.

STEP-BY-STEP CONSOLE OPERATION

Make sure that the on/off switch near the power cord is in the on position. Next, make sure that the key is removed from the console and the power cord is properly plugged in (see HOW TO PLUG IN THE POWER CORD on page 8).

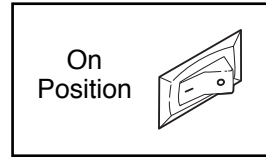

When you are ready to begin exercising, step onto the foot rails of the treadmill. Find the clip attached to the key (see the drawing on page 9), and slide the clip onto the waistband of your clothing.

To use the manual mode of the console, follow the steps below. To use a personal trainer program, see page 12. To use iFit.com CD or video programs, refer to page 15. To use iFit.com programs directly from our internet site, see page 17.

Note: The console can display speed and distance in either miles or kilometers (see SPEED/MIN-MILE DISPLAY on page 11). For simplicity, all instructions in this manual refer to miles.

HOW TO USE THE MANUAL MODE

1 Insert the key fully into the console.

When the key is inserted, the four displays and various indicators on the console will light.

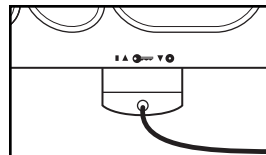

2 Select the manual mode.

When the key is inserted, the manual mode will be selected and the "M" indicator will light. If a program is selected, press the PROGRAM button repeatedly to select the manual mode.

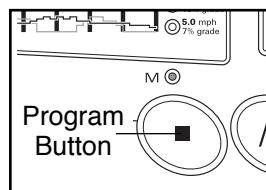

3 Press the START button or the SPEED Δ button to start the walking belt.

A moment after the button is pressed, the walking belt will begin to move at 1 mph. Hold the handrails and carefully begin walking. As you

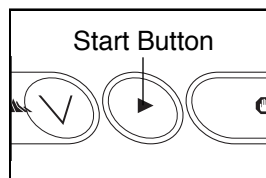

exercise, change the speed of the walking belt as desired by pressing the SPEED buttons.

To stop the walking belt, press the STOP button. The TIME/INCLINE/SEG TIME display will begin to flash. To restart the walking belt, press the START button or the SPEED Δ button.

4 Change the incline of the treadmill as desired.

To change the incline of the treadmill, press the INCLINE buttons. Each time one of the buttons is pressed, the incline will change by 0.5%. The incline range is 1.5% to 12%. Note: When one of the INCLINE buttons is pressed, the TIME/INCLINE/SEG TIME display will show the incline setting for several seconds. After the buttons are pressed, it may take a moment for the treadmill to reach the selected incline setting.

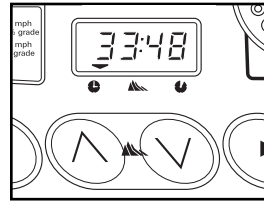

5 Follow your progress with the LED track and the four displays.

The LED Track—The LED track represents a distance of 1/4 mile. As you exercise, the indicators around the track will light one at a time until you have completed 1/4 mile. A new lap will then begin.

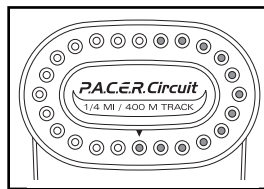

DISTANCE/LAPS display—This display shows the distance that you have walked or run and the number of laps you have completed (one lap equals 1/4 mile). The display will alternate between one number and the other every seven seconds, as shown by the arrows in the display.

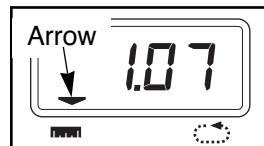

TIME/INCLINE/SEG TIME display—When the manual mode or an iFit.com program is selected, this display shows the elapsed time. When a personal trainer program is selected, this display shows both the time remaining in the program and the time remaining in the current segment of the program. The display will alternate between one number and the other every seven seconds. Each time the INCLINE buttons are pressed, this display shows the current incline setting.



HOW TO CONNECT YOUR VCR

Note: If your VCR has an unused AUDIO OUT jack, see instruction A below. If the AUDIO OUT jack is being used, see instruction B. If you have a TV with a built-in VCR, see instruction B. If your VCR is connected to your home stereo, see HOW TO CONNECT YOUR HOME STEREO on page 14.

A. Plug one end of the audio cable into the jack on the front of the treadmill near the power cord. Plug the other end of the cable into the included adapter. Plug the adapter into the AUDIO OUT jack on your VCR.

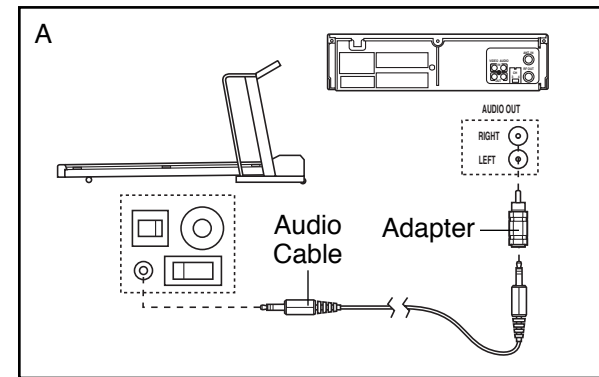

B. Plug one end of the audio cable into the jack on the front of the treadmill near the power cord. Plug the other end of the cable into the included adapter. Plug the adapter into an RCA adapter (available at electronics stores). Next, remove the wire that is currently plugged into the AUDIO OUT jack on your VCR and plug the wire into the unused side of the RCA adapter. Plug the RCA adapter into the AUDIO OUT jack on your VCR.

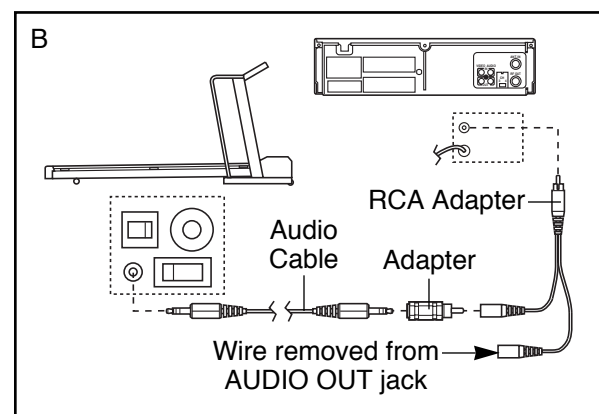

HOW TO USE IFIT.COM CD AND VIDEO PROGRAMS

To use iFit.com CD's or videocassettes, the treadmill must be connected to your portable CD player, portable stereo, home stereo, computer with CD player, or VCR. See HOW TO CONNECT THE COMPUTER TO YOUR CD PLAYER, VCR, OR COMPUTER on page 13. **Note: To purchase iFit.com CD's or to purchase iFit.com videocassettes, call 0345-089009.**

Make sure that the on/off switch near the power cord is in the on position. In addition, make sure that the power cord is properly plugged in (see HOW TO PLUG IN THE POWER CORD on page 8).

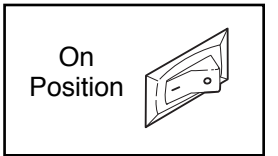

When you are ready to begin exercising, step onto the foot rails of the treadmill. Find the clip attached to the key (see the drawing on page 9), and slide the clip onto the waistband of your clothing. Follow the steps below to use an iFit.com CD or video. **Note: The instructions included in the CD case describe how to use the CD with a variety of PROFORM treadmills. Some instructions may not apply to this treadmill.**

1 Insert the key fully into the console.

When the key is inserted, the four displays and various indicators on the console will light.

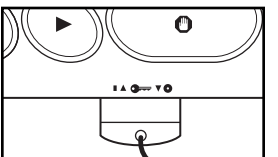

2 Press the PROGRAM button.

When the key is inserted, the manual mode will be selected. To use an iFit.com CD or video program, press the PROGRAM button. The iFit.com indicator will light.

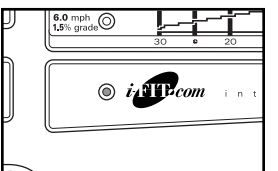

3 Insert the iFit.com CD or videocassette.

If you are using an iFit.com CD, insert the CD into your CD player. If you are using an iFit.com videocassette, insert the videocassette into your VCR.

HOW TO CONNECT YOUR HOME STEREO

Note: If your stereo has an unused LINE OUT jack, see instruction A below. If the LINE OUT jack is being used, see instruction B.

- A. Plug one end of the audio cable into the jack on the front of the treadmill near the power cord. Plug the other end of the cable into the included adapter. Plug the adapter into the LINE OUT jack on your stereo.

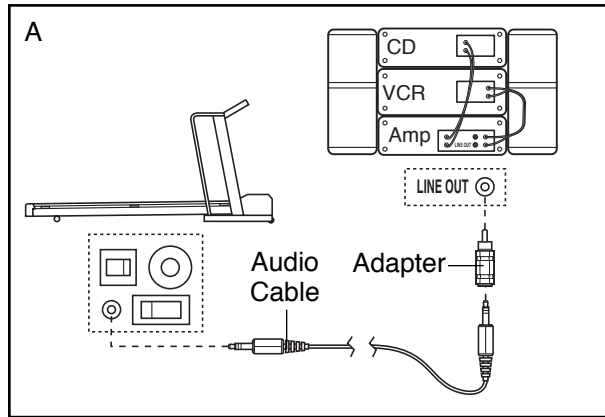

- B. Plug one end of the audio cable into the jack on the front of the treadmill near the power cord. Plug the other end of the cable into the included adapter. Plug the adapter into an RCA adapter (available at electronics stores). Next, remove the wire that is currently plugged into the LINE OUT jack on your stereo and plug the wire into the unused side of the RCA adapter. Plug the RCA adapter into the LINE OUT jack on your stereo.

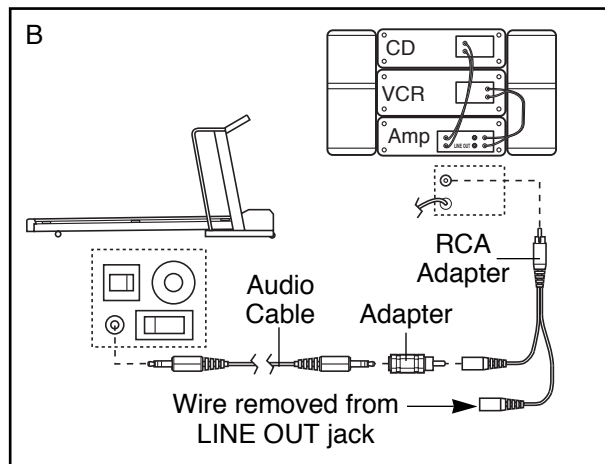

HOW TO CONNECT YOUR COMPUTER

Note: If your computer has a 3.5mm LINE OUT jack, see instruction A. If your computer has only a PHONES jack, see instruction B.

- A. Plug one end of the audio cable into the jack on the front of the treadmill near the power cord. Plug the other end of the cable into the LINE OUT jack on your computer.

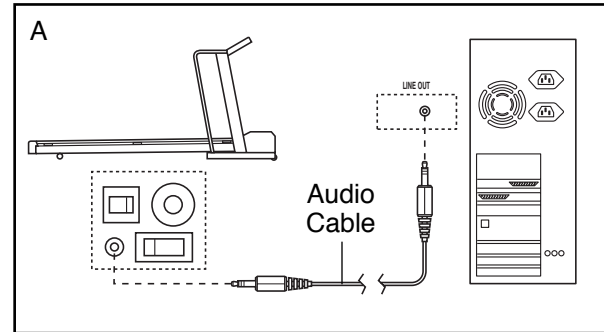

- B. Plug one end of the audio cable into the jack on the front of the treadmill near the power cord. Plug the other end of the cable into a 3.5mm Y-adapter (available at electronics stores). Plug the Y-adapter into the PHONES jack on your computer. Plug your headphones or speakers into the other side of the Y-adapter.

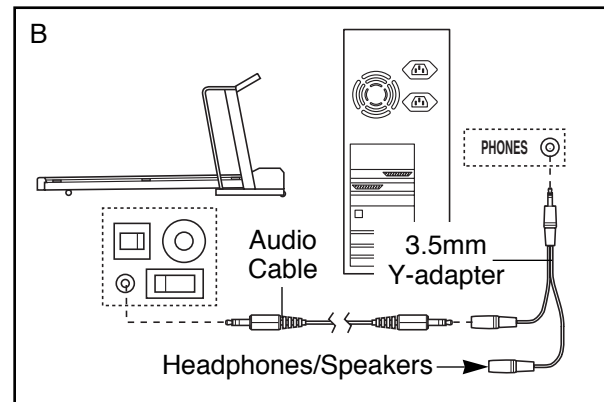

CALS/FAT CALS/PULSE display—This display shows the approximate numbers of calories and fat calories you have burned (see FAT BURNING on page 22). Every seven seconds, the display will change from one number to the other, as shown by the arrows in the display. This display will also show your heart rate when the pulse sensor is used (see step 6 on this page).



SPEED/MIN-MILE display—This display shows the speed of the walking belt and your current pace (pace is measured in minutes per mile). Every seven seconds, the display will change from one number to the other, as shown by the arrows in the display.

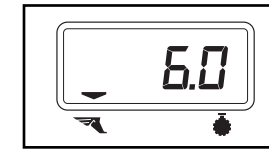

Note: The SPEED/MIN-MILE display can show speed in either miles per hour or kilometers per hour. To determine which unit of measurement is selected, hold down the STOP button while inserting the key into the console. An “E,” for english miles, or an “M,” for metric kilometers, will appear in the display. Press the SPEED Δ button to change the unit of measurement. When the desired unit of measurement is selected, remove and then reinsert the key. **Note:** For simplicity, all instructions in this manual refer to miles.

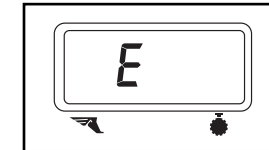

Note: To reset the displays, press the STOP button, remove the key, and then reinsert the key.

6 Measure your pulse, if desired.

Stand on the foot rails and place your hands on the metal contacts on the pulse bar. Your palms must be resting on the upper contacts, and your fingers must be touching the lower contacts—**avoid moving your hands.**

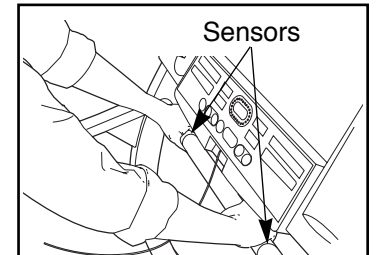

When your pulse is detected, the heart-shaped indicator in the CALS/FAT CALS/PULSE display will flash **steadily** and a series of dashes (— —) will appear. After a few seconds, your heart rate will be shown. **For the most accurate heart rate reading, continue to hold the contacts for about 15 seconds.**



7 When you are finished exercising, remove the key.

Step onto the foot rails, press the STOP button, and remove the key from the console. Keep the key in a secure place.

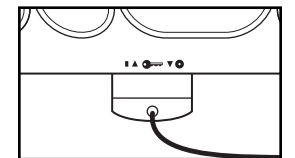

Note: If the displays and various indicators on the console remain lit after the key is removed, the console is in the “demo” mode. Refer to page 18 and turn off the demo mode.

When you are finished using the treadmill, move the on/off switch near the power cord to the off position.

HOW TO USE PERSONAL TRAINER PROGRAMS

1 Insert the key into the console.

When the key is inserted, the four displays and various indicators on the console will light.

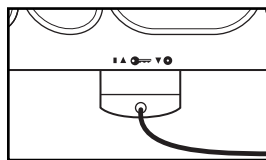

2 Select one of the personal trainer programs.

When the key is inserted, the manual mode will be selected and the "M" indicator will light. To select one of the personal trainer programs, press the PROGRAM button repeatedly until one of the six personal trainer program indicators lights.

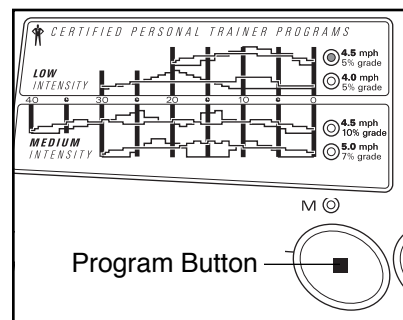

The console features two LOW INTENSITY programs, two MEDIUM INTENSITY programs, and two HIGH INTENSITY programs. The profiles on the console show how the speed and incline of the treadmill will change during the programs. The numbers beside the profiles show the maximum speed and incline settings for the programs. For example, the upper left profile shows that the treadmill will reach a maximum speed of 4.5 mph and a maximum incline of 5% during the first program.

3 Press the START button or the SPEED Δ button to start the program.

A moment after the button is pressed, the treadmill will automatically adjust to the first speed and incline settings for the program. Hold the handrails and begin walking.

Each program is divided into several time segments of different lengths. The TIME/INCLINE/SEG TIME display shows both the time remaining in the program and the time remaining in the current segment of the program.



One speed setting and one incline setting are programmed for each segment. When only three seconds remain in the first segment, a series of tones will sound and the treadmill will automatically adjust to the speed and incline settings for the second segment.

The program will continue in this way until the TIME/INCLINE/SEG TIME display counts down to zero. The walking belt will then slow to a stop.

If the speed or incline setting for the current segment is too high or too low, you can manually override the settings by pressing the SPEED or INCLINE buttons on the console. **However, when the next segment begins, the treadmill will adjust to the next speed and incline settings of the program.**

To stop the program, press the STOP button. The TIME/INCLINE/SEG TIME display will begin to flash. To restart the program, press the START button or the SPEED Δ button. To end the program, press the STOP button, remove the key, and then reinsert the key.

4 Follow your progress with the LED track and the four displays.

Refer to step 5 on page 10.

5 Measure your pulse, if desired.

See step 6 on page 11.

6 When the program is completed, remove the key from the console.

When the program has ended, remove the key from the console. Keep the key in a safe place.

Note: If the displays and indicators on the console remain lit after the key is removed, the console is in the "demo" mode. Refer to page 18 and turn off the demo mode.

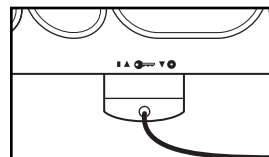

When you are finished using the treadmill, move the on/off switch near the power cord to the off position.

HOW TO CONNECT THE TREADMILL TO YOUR CD PLAYER, VCR, OR COMPUTER

To use iFit.com CD's, the treadmill must be connected to your portable CD player, portable stereo, home stereo, or computer with CD player. See pages 13 and 14 for connecting instructions. **To use iFit.com videocassettes**, the treadmill must be connected to your VCR. See page 15 for connecting instructions. **To use iFit.com programs directly from our internet site**, the treadmill must be connected to your home computer. See page 14 for connecting instructions.

HOW TO CONNECT YOUR PORTABLE CD PLAYER

Note: If your CD player has separate LINE OUT and PHONES jacks, see instruction A below. If your CD player has only one jack, see instruction B.

A. Plug one end of the audio cable into the jack on the front of the treadmill near the power cord. Plug the other end of the cable into the LINE OUT jack on your CD player. Plug your headphones into the PHONES jack.

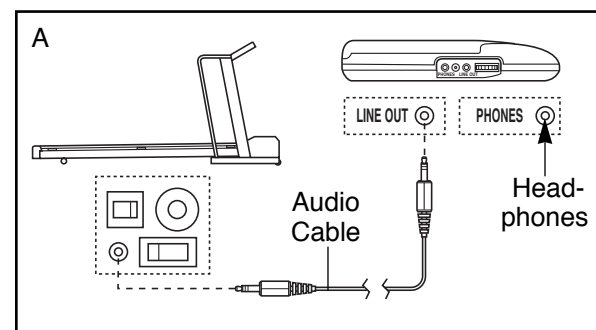

B. Plug one end of the audio cable into the jack on the front of the treadmill near the power cord. Plug the other end of the cable into a 3.5mm Y-adapter (available at electronics stores). Plug the Y-adapter into the PHONES jack on your CD player. Plug your headphones into the other side of the Y-adapter.

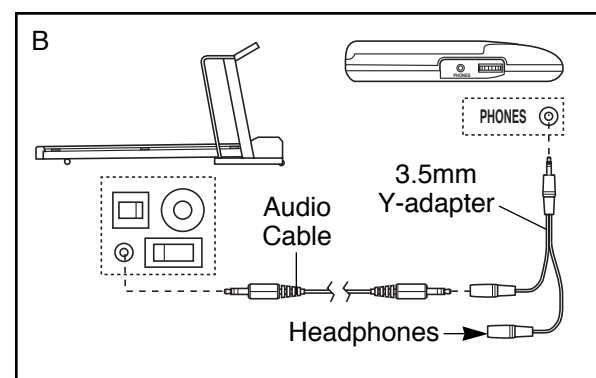

HOW TO CONNECT YOUR PORTABLE STEREO

Note: If your stereo has an RCA-type AUDIO OUT jack, see instruction A below. If your stereo has a 3.5mm LINE OUT jack, see instruction B. If your stereo has only a PHONES jack, see instruction C.

A. Plug one end of the audio cable into the jack on the front of the treadmill near the power cord. Plug the other end of the cable into the included adapter. Plug the adapter into an AUDIO OUT jack on your stereo.

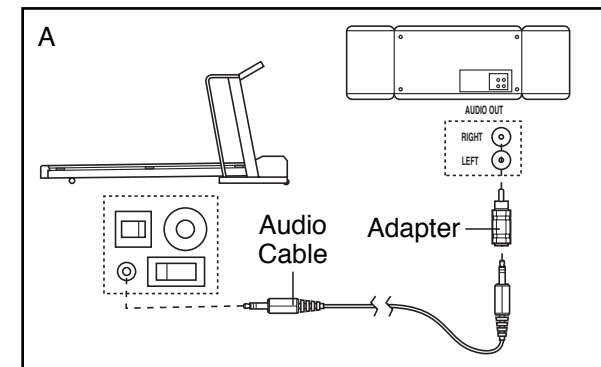

B. Plug one end of the audio cable into the jack on the front of the treadmill near the power cord. Plug the other end of the cable into the LINE OUT jack on your stereo.

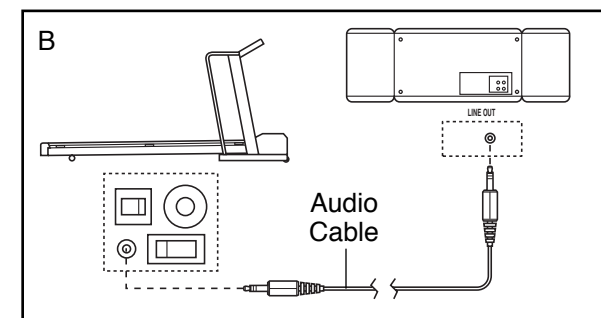

C. Plug one end of the audio cable into the jack on the front of the treadmill near the power cord. Plug the other end of the cable into a 3.5mm Y-adapter (available at electronics stores). Plug the Y-adapter into the PHONES jack on your stereo. Plug your headphones into the other side of the Y-adapter.

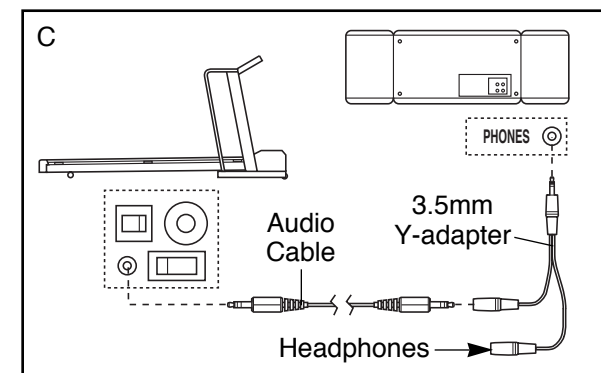

EXPLODED DRAWING—Model No. PETL61591

R1000A

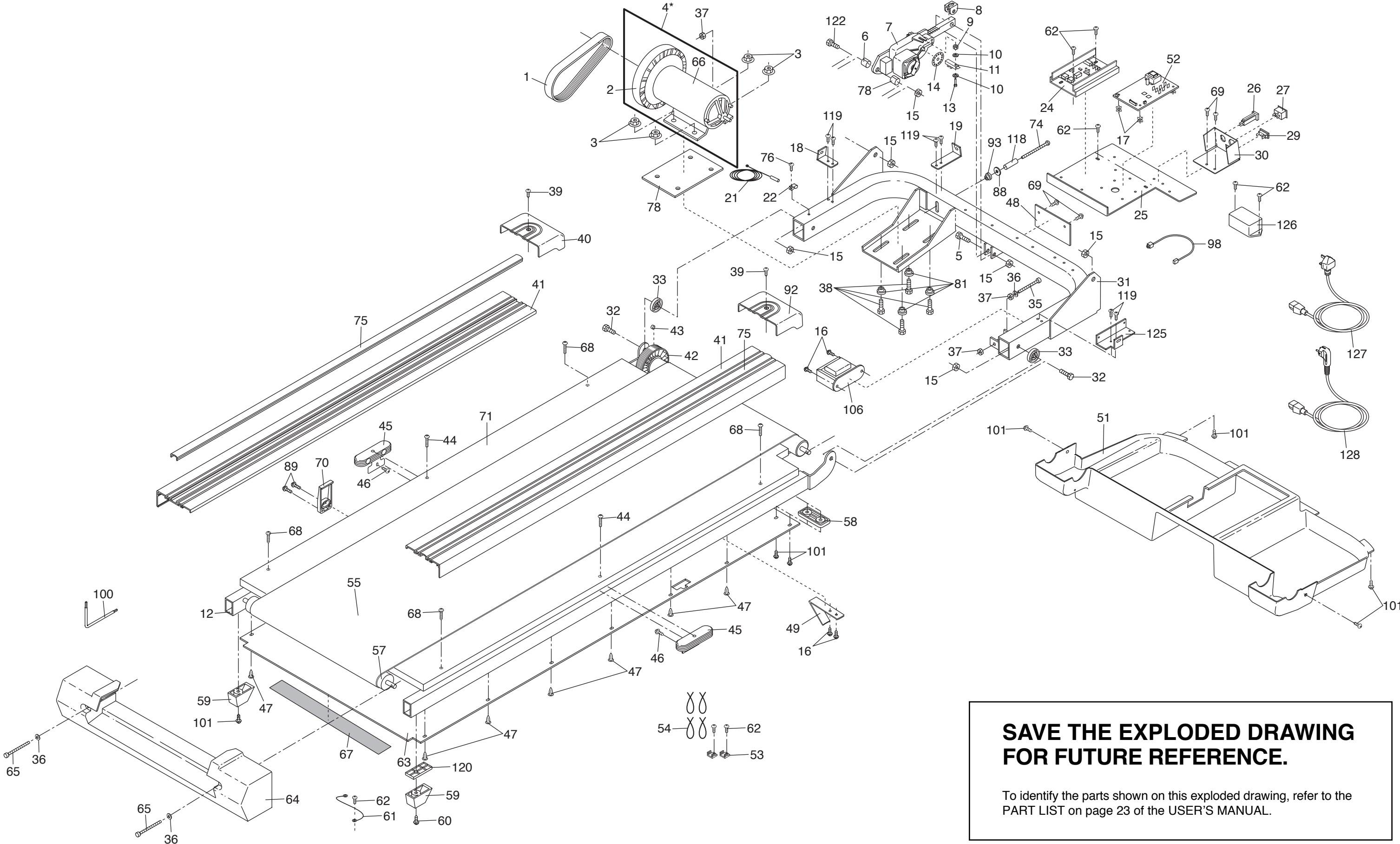

SAVE THE EXPLODED DRAWING FOR FUTURE REFERENCE.

To identify the parts shown on this exploded drawing, refer to the PART LIST on page 23 of the USER'S MANUAL.

EXPLODED DRAWING—Model No. PETL61591

R1000A

